



CT-500 Console Air Cleaner

Installation Instructions & Consumer Information



Dynamic console air cleaners utilize the patented Dynamic electronic polarized-media air cleaner in an attractive portable cabinet for applications where a high efficiency air cleaner is needed in a confined space. The Dynamic electrically enhanced media combines elements of both electronic and media air cleaners to collect particles and odors. Whether for a boardroom, or a bedroom, an office, or a kitchen, the Dynamic console is engineered to do the job. At 500cfm, the CT-500 is one of the largest room units available and offers unsurpassed air cleaning capacity. Great for allergy and asthma sufferers, pet owners, and unsurpassed for performance at removing tobacco smoke.

Features & Benefits:

INSTALLS ANYWHERE

- Plugs directly into 110V wall outlet.

EFFICIENT

- 97% efficient at .3 microns. Efficiency increases as the media fibers load.

SAFE, QUIET OPERATION

- Cabinet and motor are engineered for quiet and dependable operation.
- Does not produce ozone or arcing like other electronic air cleaners.
- Does not produce charged (ionized) particles that collect on clothes, walls and furnishings.

REMOVES ODORS

- The patented Dynamic activated-carbon center screen is effective in removing cigarette smoke, pollen, dust, odors, and other contaminants.

EASY MAINTENANCE

- No washing of components required.
- Dynamic disposable media pads are generally changed every 3-4 months and require only a few minutes to change.

WARRANTY

- Backed by a (5) Year Limited Warranty.

Specifications:

<u>MODEL</u>	<u>CT-500</u>
Airflow Capacity:	500cfm (500 fpm)
Electrical Input:	110V / 1 / 60Hz
Power Consumption:	300W max.
Speed Control:	2 speed
Cabinet Finish:	woodgrain, black
Unit Dimensions:	26"h x 23.75"w x 11"d (660mm x 605mm x 280 mm)
Weight:	43 lbs. (19.5 kg)
Airflow Pattern:	rear intake / side discharge
Filter Access:	rear of unit
Pad Change Rate:	2-4 times/year typical
db level @1m (front):	58db hi speed 54db lo speed

Care & Cleaning:

Replacement media pads are available through your dealer, or online at www.DynamicAQS.com. Media pads should generally be replaced every 3 to 4 months, depending on household conditions (applications where smokers are present may require more frequent changes depending on smoke levels). When the unit is new, it is suggested that the media pad be inspected and/or replaced after one month of operation due to the initial cleanup of contaminants. For proper operation, use only genuine Dynamic replacement media pads. Other filter material may cause the unit to operate improperly and will void the unit warranty.

- Turn the unit switch to the "off" position and unplug the unit.
- Remove the screw in the swing latch if so equipped. (As an extra safety precaution, a factory installed screw is installed in the swing latch. It can be re-used or discarded - Figure 1)
- Open the replacement media pad enclosure in the air cleaner as shown in Figure 2.
- Carefully remove the dirty media pad and discard (a plastic trash bag works well). If dust has accumulated on the outer screen of the air cleaner, clean with a vacuum or soft, damp cloth.
- Properly position the new Dynamic replacement media pad so that the media covers the entire filter space.
- Close the rear screen and replace the screw in the swing latch.
- Plug in the unit and turn the switch on.
- Position the unit several inches away from walls and furniture to allow for sufficient airflow to the air intake on the back of the console cabinet. Placing the unit diagonally across the corner of a room works well.
- Make a record of the date you replaced the media pad and make a note on your calendar for the next replacement depending on usage and lifestyle.

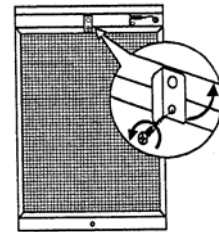

Figure 1

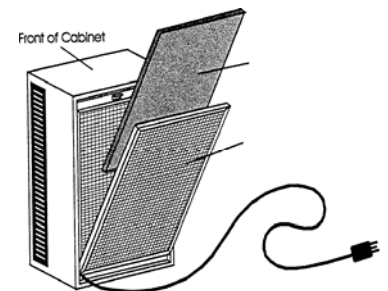
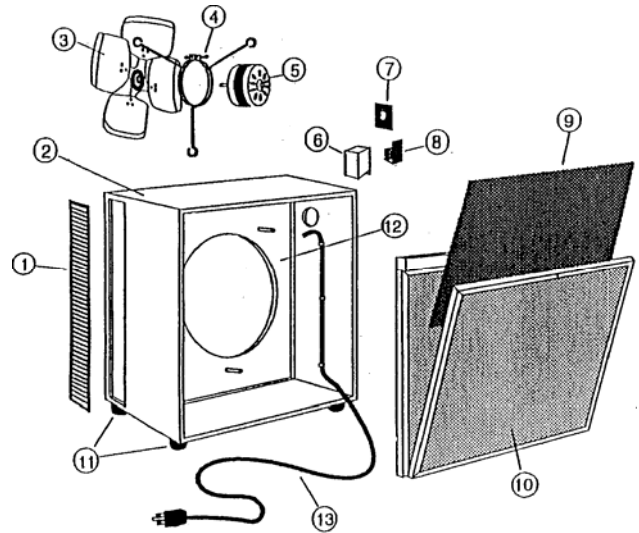

Figure 2

Replacement Parts:

CT500	Description
1	Exhaust Grill (2)
2	Cabinet
3	Fan
4	Fan Bracket (Spider)
5	Motor
6	Transformer Cover
7	Switch Plate
8	Transformer
9	Replacement Media Pad
10	Air Cleaner & Powerhead
11	Casters
12	Motor Mount Housing
13	Power Cord



Replacement Media Pads:

CCT-500: Order Dynamic Part No. 3-Pack C3PCT500 24-Pack C24PCT500

Troubleshooting:

Unit does not come on:

1. Check that the unit is plugged in and try another electrical appliance in the same outlet. If another appliance fails to start, check your central fuse box.
2. Check the power indicator light and the wiring connection on the back of the unit – Figure 3

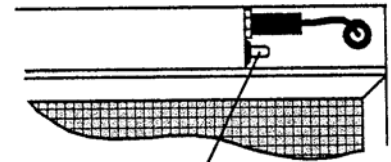

Figure 3

Snapping (arcing):

Some new media pads may snap if they have been exposed to moisture. Turn off the unit and wait for the excess humidity to disperse.

WARNING: FAILURE TO CHANGE THE MEDIA PAD ON A REGULAR BASIS COULD REDUCE AIRFLOW, CAUSE DAMAGE TO THE UNIT, AND VOID THE PRODUCT WARRANTY.

For Technical Support, call 1-800-578-7873 (9:00 am - 5:00 pm EST)

Dynamic Air Quality Solutions
P.O. Box 1258
Princeton, NJ 08542
Tel: (800) 578-7873
Fax (609) 924-8524
www.DynamicAQS.com

Specifications are subject to change without notice. Dynamic and Dynamic Air Quality Solutions are registered trademarks of Environmental Dynamics Group, PO Box 1258, Princeton, NJ 08542

©2006 EDG

DYN-220 (03/08)